



**TRANSLATION OF THE ORIGINAL GERMAN**  
**OPERATING INSTRUCTIONS**

SLSM



**INSTALLATION MANUAL**  
**MAINTENANCE MANUAL**  
**SYSTEM MANUAL**

**EN | V 1.01 | DCL 117**



# TABLE OF CONTENTS

<b>1</b>	<b>General</b>	<b>1</b>
1.1	About these instructions	1
1.2	Symbols	1
1.3	Copyright protection	2
1.4	Disclaimer	3
1.5	Customer service	3
1.6	Warranty	4
1.6.1	Warranty terms and conditions	4
<b>2</b>	<b>Safety instructions</b>	<b>5</b>
2.1	Safety	5
2.2	Intended use	5
2.3	General risks	6
2.3.1	Danger from electrical energy	7
2.4	Responsibilities of the operating company	8
2.5	Personnel requirements	9
2.5.1	Qualifications	9
2.6	Personal protective equipment	10
2.7	Safety devices	11
2.8	Conduct in case of danger or accident	11
2.9	Signage	12
<b>3</b>	<b>Technical data</b>	<b>13</b>
<b>4</b>	<b>Layout and function</b>	<b>14</b>
4.1	Brief system description	14
4.2	Assembly overview	15
<b>5</b>	<b>Commissioning</b>	<b>17</b>
5.1	Safety instructions for commissioning	17
5.2	Installation	18
5.2.1	Hanger preparation	18
5.2.2	Installation System	19
5.2.3	Installing current collector	20
<b>6</b>	<b>Maintenance</b>	<b>21</b>
6.1	Safety information about repairs	21
6.2	Rail maintenance	23
6.3	Current collector maintenance	24
<b>7</b>	<b>Transport and storage</b>	<b>25</b>
7.1	Safety instructions for transport and storage	25
7.2	Transport inspection	25
7.3	Storage	25
<b>8</b>	<b>Disassembly and disposal</b>	<b>26</b>
8.1	Disassembly	26
8.2	Disposal	27
	<b>Index</b>	<b>28</b>

# 1 GENERAL

## 1.1 About these instructions

## 1.2 Symbols

Safety instructions in this manual are identified by symbols. Each safety instruction begins with signal word that indicates the severity of the hazard. The various types of warnings and safety instructions and their structure are explained below.



### **DANGER!**

**The source of the hazard is described here.**

This combination of a symbol and a signal word indicates an immediately dangerous situation that will result in death or serious injury unless avoided.

► The actions to prevent the hazard are identified here

---



### **DANGER!**

**The source of an electrical hazard is described here.**

This combination of a symbol and a signal word indicates an immediately dangerous situation related to electricity that will result in death or serious injury unless avoided.

► The actions to prevent the hazard are identified here

---



### **WARNING!**

**The source of the hazard is described here.**

This combination of a symbol and a signal word indicates a potentially dangerous situation that may result in death or serious injury unless avoided.

► The actions to prevent the hazard are identified here

---



### **CAUTION!**

**The source of the hazard is described here.**

This combination of a symbol and a signal word indicates an potentially dangerous situation that may result in light or moderate injury unless avoided.

► The actions to prevent the hazard are identified here

---



### **NOTICE!**

**The source of the hazard is described here.**

This combination of a symbol and a signal word indicates a potentially dangerous situation that may result in property or environmental damage unless avoided.

► The actions to prevent the hazard are identified here

---

**NOTICE!**

**This indicates a reference to another place in this text or another document.**

This combination of a symbol and a signal word indicates a reference to another place in this text or in a different document.

- ▶ The places in the text or references to other documents are identified here.

**TIPS AND RECOMMENDATIONS!**

- ▶ Simple tips and recommendations from our long years of experience are provided here.

## 1.3 Copyright protection

The contents of this manual are protected by copyright. Their use is permitted within the scope of the use of the installation. No further use is permitted without the written permission of the manufacturer. This manual may not be copied, given to any third party, reproduced in any form or by any means, including, but not limited to, exploitation and / or communication of the contents without the written permission of the manufacturer, except for internal purposes.

## 1.4 Disclaimer

The information in this document has been compiled in consideration of applicable standards and regulations, accepted rules of engineering, as well as our years of knowledge and experience.

**The manufacturer shall not be liable for damages resulting from:**

- Failure to observe the technical documentation
- Uses other than the intended use
- Use by personnel without the required training
- Unauthorized modifications or technical changes
- Use of non-approved spare parts or accessories

The actual scope of delivery may vary from the descriptions and images in this document in case of custom versions, the selection of additional order options, or due to latest technical changes.

The obligations agreed in the supply contract, the general terms and conditions and the terms and conditions of delivery, and the laws and regulations applicable at the time the contract was signed all apply.

We reserve the right to make technical changes to improve the usability and for further development.

## 1.5 Customer service

<b>Paul Vahle GmbH &amp; Co. KG</b>
Westicker Str. 52
Tel: +49 (0) 2307 704-0
Fax: +49(0) 2307 704-4 44
59174 Kamen, GERMANY
E-mail: <a href="mailto:info@vahle.de">info@vahle.de</a>
Web: <a href="http://www.vahle.de">http://www.vahle.de</a>
Country of origin: Germany

## 1.6 Warranty

### 1.6.1 Warranty terms and conditions

The information in this document has been compiled in consideration of applicable standards and regulations, accepted rules of engineering, as well as our years of knowledge and experience.

The warranty period and the scope of the warranty are defined in the terms of your contract and the terms and conditions of delivery of Vahle GmbH & Co. KG.

Our general terms of warranty and delivery are published on our website.

[www.vahle.de](http://www.vahle.de)



#### WARNING!

##### **No liability in case of unauthorized changes, modifications, or accessories!**

Changes or modifications to the delivered product require the permission of the manufacturer. Genuine spare parts and manufacturer-approved accessories provide safety. The use of non-approved parts voids any liability of the manufacturer.

► Always consult the manufacturer first!

**The warranty becomes void in case of any of the events below:**

- The product is changed without permission from Vahle.
- The buyer performs the assembly or repairs himself during the warranty period or has repairs performed by third parties.
- If the product has been handled or maintained inappropriately.
- Use of spare parts that are not genuine Vahle parts.
- Failure to observe the information in this documentation.



## 2 SAFETY INSTRUCTIONS

### 2.1 Safety

This section gives an overview of all important safety aspects relating to the protection of personnel as well as the safe use and fault-free operation. Other, task-specific safety instructions can be found in the sections on the individual phases of the product's life.



 **DANGER!**

**Failure to observe the safety instructions may result in risks to life and health!**

### 2.2 Intended use

#### Intended use

The charge contacts are intended for charging moving shuttles which travel over the bar with the built-in current collector.

- Ambient temperature: - 30 °C to +55 °C
- Air humidity: RH 95% (non-condensing)
- Service life of the charging contacts until replacement: 6 years
- Travel speed: Max. 4.0 m/s
- Acceleration: 1.0 m/s<sup>2</sup>
- Transitions/year: Approx. 1,000,000
- Voltage: 0 to 48VDC
- Max. current load: 40A, 60A peak
- Automatic shut-off of the charging current by the power supply units when raising or lowering the charging contacts
- Only for indoor systems
- Length of the charging contact max. 5 m. Longer charging contacts on request

#### Foreseeable misuse

- Incorrect installation
- Insufficient air gap in relation to surrounding, possibly conductive parts
- Insufficient maintenance
- Temperature range exceeded





## 2.3 General risks

The following section describes residual risks that arise even if the device is used as intended. Observe the safety instructions listed here in the other sections of these instructions to reduce the risk of injuries or damage to property and equipment and to avoid dangerous situations.

Do not change or modify the system inappropriately!



### **WARNING!**

#### **Risk of death from improper replacement or removal!**

Errors during the removal or replacement of components may cause life-threatening situations or significant property damage

- ▶ Observe the safety instructions before beginning any removal work.
-



### 2.3.1 Danger from electrical energy

Perform the following safety work according to VDE 0105-100 (this work must be carried out by a qualified electrician, see chapter: "2 security").

#### Activate

The required separation distances must be established.

#### Secure against restart

During work, a prohibition sign must be attached reliably on switching handles or drives of switches, control units, pressure and sensing devices, safety parts, circuitry breakers that have been used to unlock a system part or that can be used to connect electricity. If this is not possible, then the clearly associated prohibition sign must be nearby. Existing mechanical interlocking devices against restart must be used for manually operated switches.

#### Determine absence of voltage

Absence of voltage is to be determined at or as close as possible to the work site at all poles. Absence of voltage must be checked with a voltage tester immediately before and after use.

#### Grounding and short-circuiting

Parts on which work will be performed at the work place must first be grounded and then short circuited. Grounding and short-circuiting must be visible from the workplace. Deviating from the above, it is permitted to ground and short-circuit near the work place if this is required due to local conditions or for safety reasons. Devices for grounding and short-circuiting must always first be connected with the grounding system or the ground electrode and afterwards with the parts to be grounded. Grounding and short circuiting may be waived in certain low-voltage systems (see VDE 0100-100).

#### Cover adjacent, live parts or isolate them

Before starting work, check whether it is appropriate to make adjacent parts voltage-free.



#### DANGER!

##### Danger of life due to electrical current!

Contact with live parts can result in life-threatening injuries.

- Make sure that the components are not live or in tension unauthorized approximation.



## 2.4 Responsibilities of the operating company

### Definition of the operating company

The owner is listed in the order confirmation and has the following owner obligations:

### Owner obligations

The system is put to commercial use. The owner of the system is therefore subject to laws and regulations on workplace health and safety. In addition to the safety instructions in this document, the safety, accident prevention, and environmental regulations for the system's field of application must be followed. The following applies in particular:

- The owner ensures protection against electric shock (contact protection).
- The owner must inform himself about applicable workplace health and safety regulations and conduct a risk assessment for additional hazards that may arise from the special operating conditions at the installation site. These must be implemented as facility instructions for the operation of the system.
- Over the entire time, the owner has to verify that the instructions drafted by him for the operation of the system conform to the current state of applicable regulations and adapt the instructions as necessary.
- The owner must clearly define responsibilities for the installation, operation, maintenance, and cleaning of the system.
- The owner must ensure that all employees who handle the system have read and understood the operating instructions. The owner is also required to provide training periodically and instruct personnel about the risks.

**The owner is also responsible for ensuring that the system is always in good technical condition. The following therefore applies:**

- The owner must ensure that the maintenance intervals described in this documentation are observed.
- Control and safety devices provided by the owner for the operation of the system must be checked for completeness and functional safety.
- The owner must ensure that assembly and installation comply with EN 60204.
- The owner must ensure that all components are de-energized in the event of an emergency off. This applies in particular to the parallel busbar.



## 2.5 Personnel requirements

### 2.5.1 Qualifications

The tasks described in this manual present various requirements to the qualifications of the persons performing them.



#### WARNING!

##### **Hazard in case of insufficient qualification of personnel!**

Insufficiently qualified persons are unable to judge the risks when working on the system, which puts them and others at risk if severe or fatal injuries.

- ▶ All work must be performed by qualified personnel only.
- ▶ Insufficiently qualified personnel must stay out of the work area.

#### **Operator**

The operator has been instructed by the owner about the tasks assigned to him and the risks of inappropriate actions. An operator may perform tasks that go beyond normal operation only if this is indicated in the instructions and the owner has expressly assigned him with such a task.

#### **Electrically qualified person (see VDE 0105-100)**

Due to their professional training, knowledge, experience, and knowledge of the relevant standards and regulations, professional electricians are able to carry out work on electrical installations and to independently recognize and avoid possible hazards. The professional electrician has been specifically trained for his/her professional working environment and is conversant with the relevant standards and regulations.

#### **Qualified personnel**

Qualified personnel are able, based on their technical training, knowledge, experience, and familiarity with applicable regulations, to perform the assigned tasks and independently detect and avoid potential hazards.

#### **Instructed personnel**

The instructed person has been instructed by the owner about the assigned tasks and the risks of inappropriate actions. Such persons must also have read and understood these safety instructions and observe them during their work.

This may need to be confirmed by the customer/user with a signature.



## 2.6 Personal protective equipment

Every person who is instructed to work on the system or in the vicinity of the system (support personnel) must wear personal protective clothing/equipment for the suitable type of their work. Personal protective equipment has the purpose of protecting personnel against hazards to their health and safety at work. The owner is responsible to ensure that protective equipment is worn.

Personal protective equipment is described below:



### Safety shoes

Safety shoes protect against falling parts as well as against slipping.



### Protective goggles

Protective goggles protect against flying particles and liquid sprays.



### Helmet

Helmets protect against falling or flying parts and materials.



### Gloves

Gloves protect hands against chafing and abrasion, cuts and punctures, as well as against contact with hot surfaces.



### Protective work clothes

Work clothing is close fitting and resistant to tearing, with close-fitting sleeves and without any projecting parts. It is designed to protect against being caught by moving parts of machinery. However, it must not reduce mobility. Do not wear rings, necklaces, or other jewelry. Long hair must be covered (cap, hat, hairnet or similar). Fall-arrest equipment, face and hearing protection acc. to DGUV Regulation 112-189.



### Hearing protection

To protect against severe and permanent hearing loss.



### Breathing protection

To protect against severe and chronic conditions of the airways.



## 2.7 Safety devices



### WARNING!

#### **Danger from non-functional safety devices!**

Non-functional or disabled safety devices cause a risk of severe injuries or even death.

- ▶ Before beginning any work, verify that all safety devices are functional and installed properly.
- ▶ Never disable or override safety devices.

In addition to locally applicable safety regulations, the following safety instructions must be observed.

The following accident prevention regulations (UUV; Germany), respectively the new Accident Prevention Regulations – Principles of Prevention (DGUV Regulation 1; Germany) must always be observed.

## 2.8 Conduct in case of danger or accident

### Precautions:

- Have first-aid equipment (first-aid kit, blankets etc.) and fire extinguisher ready.
- Maintain free access for emergency services vehicles.

### Conduct in case of accident:

- Secure site of accident and call first aid personnel.
- Alert emergency services.
- Provide first aid



## 2.9 Signage

The following symbols and information signs may be in the work area. They apply to the immediate environment of their location.



### **DANGER!**

#### **Danger of life due to electrical current!**

Contact with live parts can result in life-threatening injuries.

- ▶ Make sure that the components are not live or in tension unauthorized approximation.



### **WARNING!**

#### **Hazard from illegible signs!**

Over time, labels and signs may become soiled or otherwise illegible so that hazards may not be recognized or necessary operating instructions may not be followed.

- ▶ Always keep all safety, warning and operating instructions in easily legible condition.



### *NOTICE!*

#### **Observe instructions!**

Use the identified device only after this documentation has been read and understood in full.



### 3 TECHNICAL DATA

Technical specifications		
Power supply, 2 poles	[V DC]	48
Traveling speed	[m/s]	4
Acceleration	[m/s <sup>2</sup> ]	1
Charging current	[A]	40 (60 peak)
Operating temperature	[° C]	-30 to +55





## 4 LAYOUT AND FUNCTION

### 4.1 Brief system description

The SLSM system is distinguished by its compact construction which makes it ideal for installation in the guide rail. The system continues to offer the following properties:

- Modular structure for variable system lengths
- High advance rates for optimal utilization of system efficiency
- Extremely wear-resistant ramp elements for long service life
- Can be traveled on both sides for loading positions even in the lane
- High charging currents (up to 100 amps with 2 feed terminals) Ideal for loading systems with 24/48 volt applications.



## 4.2 Assembly overview

### Access ramp

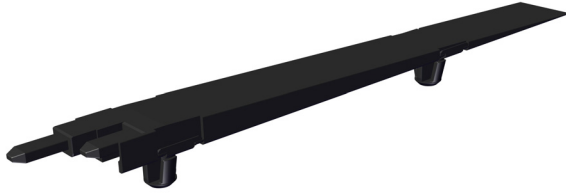

Access ramp AFR-265-SLSM-2-100		
ID no.		0590708/00
Length	[mm]	265
Width	[mm]	30
Height	[mm]	12
Incline	[°]	2.6
Grating hanging	[mm]	50

### Feed terminal



Feed terminal ES-SLSM-2-100		
ID no.		0590706/00
Number of poles:		1x +pole 2x -pole
Max. current	[A]	50 at 100 % duty cycle
Length	[mm]	400
Width	[mm]	30
Height	[mm]	12
Grating hanging	[mm]	50
Asymmetrical structure		
Mechanical reverse polarity protection (for two consecutive feed terminals)		
Screwing technology for rail fastening		
Connection type: flat connector 6.3 x 0.8 mm		

### Contact rail



Contact rail KS-SLSM-2-100		
ID no.		0590707/00
Max. current	[A]	100 for 100 % duty cycle (for 2 50 A feed terminals)
Length	[mm]	400
Width	[mm]	30
Height	[mm]	12
Grating hanging	[mm]	50
Screwing technology for rail fastening		



## Hanger

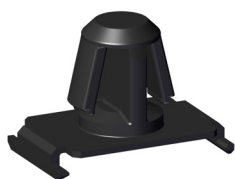

## Hanger AH-SLSM-4-13,5

ID no.	0590709/00
Plate thickness	[mm] 4

## Plug connector

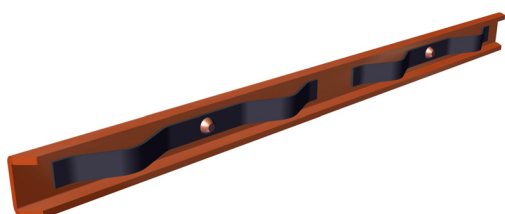

## Plug connector VM-STV-100-SLSM

ID no.	0590710/00
Max. current	[A] 100 at 100 % duty cycle
Length	[mm] 120
Width	[mm] 8
Height	[mm] 3.5 (3.6 with spring)
Beryllium springs are riveted	

## Current collector

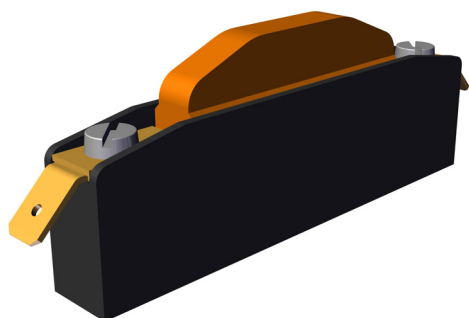

## Current collector ONST 25

ID no.	0590711/00
Max. current	[A] 25 at 100 % duty cycle
Application pressure	[N] 5
Length	[mm] 78
Width	[mm] 11
Installation height	[mm] 31
With 25 A 100 % ED, use of both flat connectors (6.3 x 0.8 mm)	



## 5 COMMISSIONING

### 5.1 Safety instructions for commissioning



#### WARNING!

##### **Risk of injury in case of improper operation!**

Improper operation may result in serious injury or property damage.

- ▶ Observe the safety instructions from chapter “2 Safety instructions.”
- ▶ Are all acceptance reports available? (initial startup)
- ▶ Are there no people in the danger zones?
- ▶ Was the assembly performed completely according to instructions?
- ▶ Have excess materials, tools and auxiliary devices been cleared from the danger zones?
- ▶ Have the electrical system powered up by an authorized electrically trained person (see chapter “2 Safety instructions”)



#### WARNING!

##### **Danger to unauthorized persons!**

Unauthorized persons who do not fulfill the requirements described here may not be aware of the hazards in the relevant working areas.

- ▶ Keep unauthorized persons clear of the work area
- ▶ If in doubt, address the relevant person and instruct them to leave the work area if necessary
- ▶ Interrupt work until unauthorized persons have left the work area



#### WARNING!

##### **Hazard in case of insufficient qualification of personnel!**

Insufficiently qualified persons are unable to judge the risks when working on the system, which puts them and others at risk if severe or fatal injuries.

- ▶ All work must be performed by qualified personnel only
- ▶ Insufficiently qualified personnel must stay out of the work area



#### WARNING!

##### **Risk of injury from falling parts!**

In case of improper use (faulty assembly, misuse, failure to perform maintenance, etc.), there is a risk of parts falling down.

- ▶ Wear a helmet
- ▶ Perform regular maintenance



## 5.2 Installation

### 5.2.1 Hanger preparation

Hole pattern of contact rail

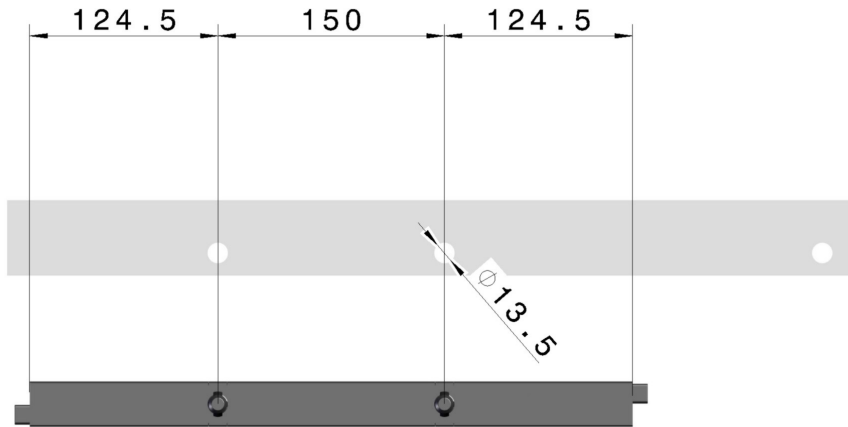

Hole pattern of feed terminal

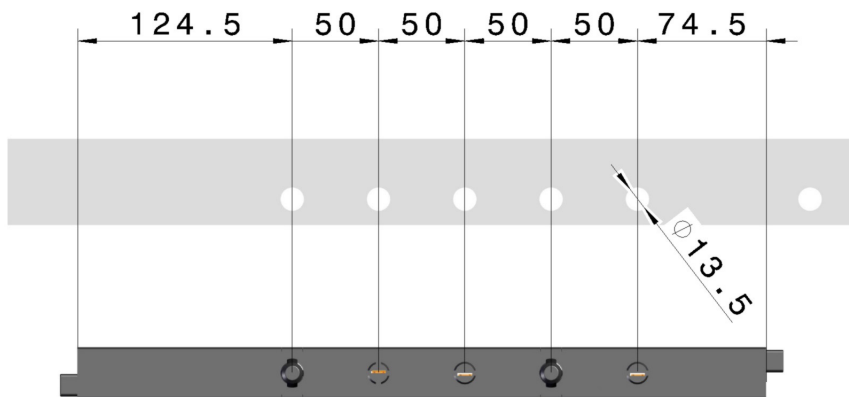

Hole pattern of access ramp

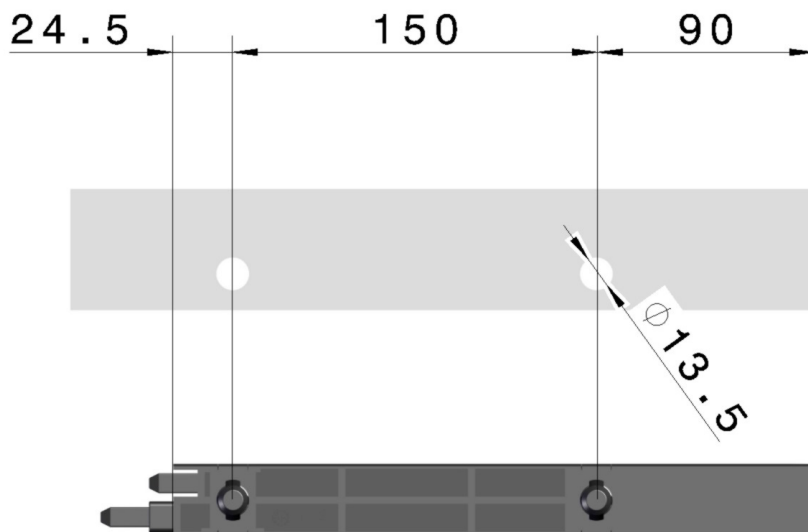



## 5.2.2 Installation System

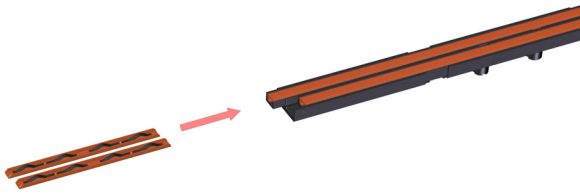

### Inserting plug connector

Assembly steps:

1. Push two plug connectors halfway into the contact bar / feed terminal.

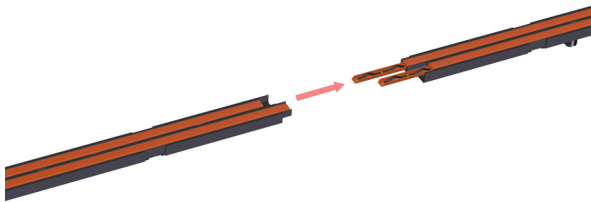

### Connecting contact bars / Connecting feed terminals

Assembly steps:

1. Connect the next contact bar / feed terminal with the plug connectors, without leaving a gap between the housings.
2. Repeat the steps until the desired number of contact bars and feed terminals has been reached.

#### NOTICE!

Observe the polarity indicators on the feed terminals and contact bars. Mechanical reverse polarity protection is only available for two consecutive feed terminals.

- Align the contact bars with the feed terminals so that the + and - markers are located on the same side.



### Attaching access ramps

Assembly steps:

1. Attach the access ramp at the beginning and the end.

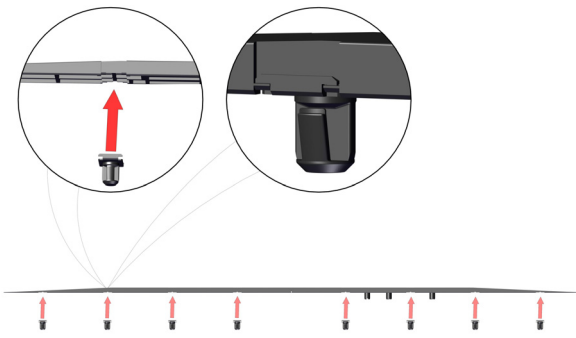

### Attaching the system

#### Requirements:

- ✓ The hole pattern is prepared according to side 18.

#### Assembly steps:

1. Clips the hangers in the bar so that they audibly engage.
2. Place the bars on the hangers in the prepared bore holes.

### Connection

#### Assembly steps:

1. Attach the flat plug to the + or - pole.
2. The additional - pole can be used for grounding the steel structure.

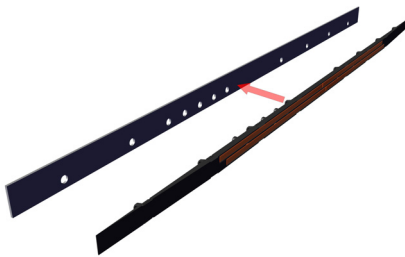

## 5.2.3 Installing current collector



#### Requirements:

- ✓ The support component for the current collector has been prepared. Observe the installation dimension of the current collector (see Current collector page 16)
- ✓ Customer-side cabling

#### Required tools:

- ✂ Screwdriver

#### Assembly steps:

1. Attach the current collector to the support component.
2. Attach the flat plug.



## 6 MAINTENANCE

### 6.1 Safety information about repairs



**⚠ DANGER!**

Before beginning any work, ensure that the system is free of voltage and remains so for the duration of the work. Observe the safety instructions from chapter “Safety”!



**⚠ WARNING!**

**Risk of injury in case of improperly executed maintenance!**

Improper maintenance may cause serious injuries or property damage.

- ▶ Ensure sufficient installation space before beginning any work.
- ▶ Ensure that the working area is clean and well organized!
- ▶ Before beginning any work, follow the procedures according to section. “Risks due to electrical energy”.



**⚠ WARNING!**

**Hazard in case of insufficient qualification of personnel!**

Insufficiently qualified persons are unable to judge the risks when working on the system, which puts them and others at risk if severe or fatal injuries.

- ▶ All work must be performed by qualified personnel only.
- ▶ Insufficiently qualified personnel must stay out of the work area.



**⚠ CAUTION!**

**Tripping hazard due to protruding parts**

There is a tripping hazard during the work.

- ▶ Watch out for steps and holes in the floor when walking inside the work area and the danger zone. There must be no loose objects in the work area.



**⚠ CAUTION!**

For maintenance and cleaning work where graphite contact dust may get into the ambient air, breathing protection must be used:

- ▶ Breathing protection mask acc. to EN 149, min. protection level FFP3.  
Vahle product ID: 10017880
- ▶ Never blow out the mask with compressed air.
- ▶ Use suction with filter class H (retrofitting of HEPA filter required).
- ▶ Do not eat, drink or smoke during work.







## 6.2 Rail maintenance

Interval	Service/monitoring tasks	Personnel
Daily	<ul style="list-style-type: none"> <li>Check safety equipment and operating behavior of the system.</li> </ul>	Operator
Monthly	<ul style="list-style-type: none"> <li>Visual inspection of general condition. Also take note of expansion of the conductor rails and of burn marks. Replace damaged burnt parts.</li> <li>Check mechanical and electrical connections, particularly on the feeds and tighten if necessary (in doing so observing the prescribed torques)</li> </ul>	Technician/electrically qualified person
If necessary	<ul style="list-style-type: none"> <li>Remove dust deposits (e.g. carbon brush dust, coupler wear debris) and other particle deposits if necessary.</li> <li>Remove any small burns or discoloration caused by corrosion on the contact surface by scouring with a non-woven abrasive. <b>Do not use a powered brush.</b> Replace the conductor rail if it is not possible to remove the burn marks.</li> </ul>	Technician/electrically qualified person

In case of damage to the conductor rails, the associated components such as current collectors must be inspected for damage.



## 6.3 Current collector maintenance

Interval	Service/monitoring tasks	Personnel
Daily	<ul style="list-style-type: none"> <li>Check safety equipment and operating behavior of the system.</li> </ul>	Operator
Monthly	<p><b>Mechanical checks</b></p> <ul style="list-style-type: none"> <li>Check mobility of joints, bearings, and hinge pins. Inspection for mechanical damage of any type.</li> </ul> <p><b>Electrical checks</b></p> <ul style="list-style-type: none"> <li>Check for wear of graphite contacts, firm seat of all contact screws and cable attachments.</li> <li>Clean oxidized contact screws and cable ends and restore the protection of these locations.</li> <li>Carbon brushes should be replaced in good time so that the mounts of the carbon brushes do not grind on the contact surface, or the outer edges of the cover plate touch the conductor rail.</li> <li>Inspection of the wear limit on the carbon brush.</li> </ul>	Technician/electrically qualified person

In case of damage to the conductor rails, the associated components such as current collectors must be inspected for damage.

### Replacing the current collector

*Requirements:*

- ✓ The system is switched off and the power supply is disconnected.

*Work steps:*

1. Pull out the power cable.
2. Remove the current collector.
3. Install the new current collector.
4. Install the connecting cable.
5. Clean the contact surfaces of the carbon brush.



## 7 TRANSPORT AND STORAGE

### 7.1 Safety instructions for transport and storage



#### NOTICE!

**Damage due to improper transport or storage. Improper transport or storage may cause significant property damage!**

- ▶ Storage temperature: 0 °C to +45 °C
- ▶ Storage location: Indoors, dry, no exposure to chemicals.
- ▶ Do not expose to direct sunlight.
- ▶ Exercise caution and observe the symbols on the packaging while unloading the pieces at delivery or during transport on the facilities.

### 7.2 Transport inspection

**Check the delivery for completeness and transport damage upon receipt!**

If any external damage is found:

- Refuse delivery or accept delivery only conditionally.
- Note the scope of the damage in the transport documents or on the carrier's delivery note.



#### NOTICE!

**The delivery may be damaged during transport!**

Report all defects as soon as they are found. Claims for damages can only be made during the applicable period.

- ▶ Document and report the defects found.

### 7.3 Storage

#### NOTICE!

When storing plastic parts, the plastic must be kept moist in order to maintain its properties.



## 8 DISASSEMBLY AND DISPOSAL

### 8.1 Disassembly



#### **DANGER!**

##### **Risk of fatal injuries from electrical current!**

Contact with electrically live components may result in fatal injuries.

- ▶ Ensure that the relevant components are not live and protected against unauthorized access.



#### **WARNING!**

##### **Risk of death through faulty exchange and disassembly!**

Errors during the removal or replacement of components may cause life-threatening situations or significant property damage

- ▶ Observe the safety instructions before beginning any removal work.



#### **CAUTION!**

##### **All accessories must be checked for wear.**

Only parts in a perfect condition may be used again.

- ▶ Only genuine VAHLE replacement parts may be used.

During replacement it is essential to observe the instructions in chapter 2.3.1 .

- Switch off the system and secure it against being switched back on.
- Physically disconnect the entire power supply from the system.
- Loosen and remove all connections.

#### **NOTICE!**

**The individual components of the system must be completely replaced in case of damage.**

For spare parts, see 4.2 Assembly overview



## 8.2 Disposal

At the end of the system's service life, the system must be disassembled and disposed of in an environmentally friendly manner according to local laws and regulations.



### *NOTICE!*

Electronics are special waste! Observe locally applicable laws and regulations for disposal.

---



## INDEX

### A

Activate 7

### D

Determine absence of voltage 7

### E

Electrically qualified person 9

### G

Grounding and short-circuiting 7

### I

Isolation 7

### O

Operating company 8

Owner obligations 8

### Q

Qualifications 9

### R

Requirements to personnel 9

### S

safety aspects 5

Safety information 2

Storage temperature 25

Switch on again 7

Symbols 1

### T

Technical condition 8

Transport 25

### U

Unloading 25



**Paul Vahle GmbH & Co. KG**

Westicker Str. 52  
D - 59174 Kamen

Tel.: +49 (0) 2307/704-0

E-Mail: [info@vahle.de](mailto:info@vahle.de)

[www.vahle.com](http://www.vahle.com)



**Technical Documentation**